

# BING Slide Carburettor Type 54-2

BING Carburetors Type 54 comprise a cross-draught slide carburettor with part-load needle jet control, idling system and starting carburettor. It is produced with a choke tube size of 34, 36, 38 and 40 mm. Since aluminium is used for the main housing, the type 54 is very light for a carburettor of this size.

## Mounting

The carburettor is secured to the motor either by a clamped connection comprising the clamp (31), the screw (32) and the nut (33) or by a push-on connection using a flexible connecting piece pushed on to intake manifold and carburettor housing. The clamp connection is produced with a diameter of 50 mm which may be reduced to 45 mm by using an insulating bush (55). The push-on connection has optional diameters of 50 and 45 mm. On the intake side the carburettor is provided with a socket having a diameter of 52 mm and a length of 16 mm for connecting an air filter or intake silencer.

## Fuel intake control

The float (24) of the carburettor consists of two plastic float elements joined by a metal hinge. The float is arranged centrally below the carburettor choke tube so that the carburettor can be tilted very far in all directions without impairing operation. The object of the float is to maintain the fuel level in the float chamber (28) constant. When the fuel has reached a specified level in the float chamber, then the float mounted on pin (25) is lifted until the float needle (26) is pressed against the seat of the float needle valve, thus preventing any further supply of fuel. When the engine draws fuel from the carburettor, the level in the float chamber (28) drops and so does the float. The float needle opens the valve again and allows fuel to flow in from the tank.

The float needle valve regulates the fuel supply in conjunction with the float but it does not act as a stop valve when the engine is at a standstill. Minute foreign bodies may be deposited between the valve seat and the needle tip, thus preventing complete closure of the valve. When stopping the engine, therefore, the fuel cock on the tank should always be closed. In addition the fuel should be filtered before it reaches the carburettor. The filter should be selected so that foreign bodies greater than 0.1 mm are filtered out and the fuel supply is not impeded to too great an extent.

The float needle (26) contains a spring-loaded plunger which contacts the float hinge. This absorbs vibrations of the float (24). In addition the float needle (26) is connected to the float hinge by the retaining spring (27) to prevent it from moving between float and valve seat and thus reducing the fuel supply. Spring and retaining guide make a considerable contribution towards keeping the fuel level in the float chamber constant.

When fitting a new float, the fuel level must be adjusted. When doing this care must be taken to ensure that the

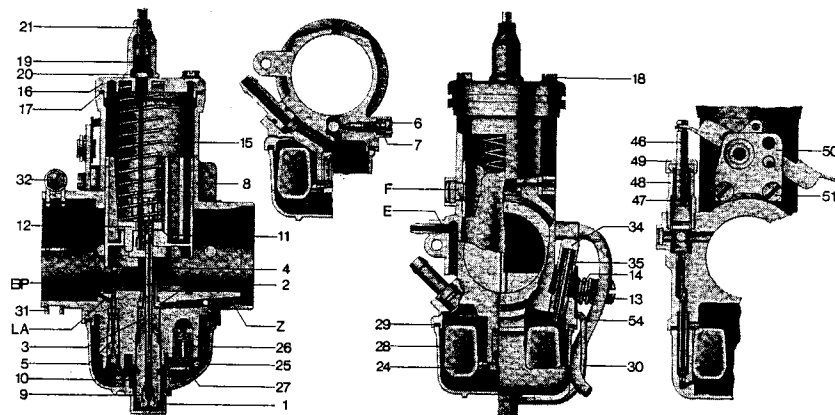

fuel needle spring is not compressed by the float weight. It is therefore advisable to put the carburettor in a horizontal position until the float just contacts the float needle. In this position the pointer on the float hinge is set in such a way that the float top edges are parallel to the top edge of the float chamber.

The float chamber (28) is secured to the carburettor housing by a spring yoke (30). A seal (29) is provided between float chamber and carburettor housing. The space above the fuel level is connected to atmosphere by two ducts. (E). When these ducts are blocked, an air cushion forms above the fuel level. The fuel will not lift the float sufficiently to close the needle valve and the carburettor overflows. The internal ports into the vent ducts are screened by a plate so that they can not be flooded by fuel. On some types the vent duct openings to atmosphere are provided with a hose (54) each, which prevents ingress of dust and water into the carburettor. The float chamber (28) incorporates an overflow pipe to allow fuel to drain off if the specified level in the float chamber is exceeded substantially due to a faulty needle valve.

## Main regulating system

The amount of mixture drawn in by the engine and thus its performance is determined by the cross-sectional area in the choke tube which is opened up by the throttle slide (8). This slide is lifted by a Bowden cable against the action of a return spring (15). The air flow produces a vacuum in the carburettor choke tube which draws fuel from the float chamber through the jet system. On its way from the float chamber to the choke tube the fuel passes through the main jet (1), the jet stock (9) and the needle jet (3); as it leaves the needle jet it is pre-mixed with air which is brought in from the filter connection via an air duct (Z) and the atomizer (2) in an annular flow around the needle jet. This air flow assists the atomizing process to form minute fuel droplets and thus favourably affects the fuel distribution in the intake manifold and combustion in the engine.

In the part-load range, in other words when the throttle slide is between one and three-quarters of its full stroke, less fuel is required than at full throttle. The fuel supply to the choke tube is therefore reduced by a jet needle (4)

which is connected with the throttle slide (8) and engages the needle jet (3). Depending on the dimension of the flat cone at the end of the jet needle, the annular gap between jet needle and needle jet is enlarged or decreased. For fine adjustment the jet needle may be located in the throttle slide in various positions (needle positions) which, similarly to the jet needle cone, affect the amount of fuel drawn in. For example a higher needle position results in a larger annular cross-section in the needle jet which allows more fuel to pass through and vice versa. For example "needle position 2" means that the jet needle has been suspended from the spring retainer (11) with the second notch from the top. When the throttle slide opening is reduced further, the amount of fuel supplied is affected also by the shape of the throttle slide at the lower end. With increasing height the cylindrical recess called air cushion results in the mixture becoming leaner. The recess on the filter side called cut-out has a similar effect but this extends up to a greater slide stroke.

The carburettor is adjusted using main jets and needle jets of various sizes and also atomizers, gas slides and jet needles of various types.

The jet needle (4) is located in the throttle slide (8) by the retainer (11). The slide spring (15) is supported by the guide piece (12) in the throttle slide (8) in such a way that the retainer (11) is secured. In addition pins at the lower end of the guide piece (12) provide a locking effect for the attachment hole for the Bowden cable in the throttle slide. A guide piece (F) (no spare part) locates the throttle slide in the carburettor housing.

The throttle slide movement is limited at the top by a sealing ring (17) and the cover plate (16) which is secured by two screws (18). The Bowden cable play is adjusted by means of an adjusting screw (19) and a lock nut (20). During idling the cable play should be approximately 3 mm. The rubber bush (21) provides a seal between adjusting screw (19) and Bowden cable. If necessary the Bowden cable may be re-routed using a pipe bend (22) with lock nut (23).

The main jet (1) is surrounded by a strainer (10); in particularly severe operating conditions this ensures that the fuel is not spun away from the main jet. The strainer (10) does not act as a filter!

### Idling system

During idling the throttle slide is closed to such an extent that it touches the slide adjusting screw (13). This screw allows the idling speed to be changed. If it is turned in clock-wise direction the idling speed is increased and vice versa. The spring (14) ensures that the adjusting screw (13) cannot work loose.

In the idling position the vacuum at the needle jet outlet is so low that the main regulating system will no longer

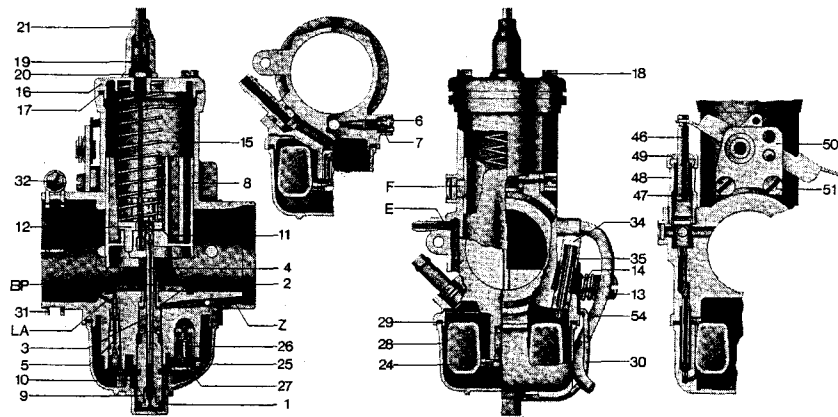

supply any fuel. This is then supplied via an auxiliary system, the idling system, which consists of the idling jet (5) and the mixture control screw (6) with sealing ring (7) which acts as a seal for the screw and also stops it from working loose.

The fuel passes through the idling jet (5) whose bore will determine the amount of fuel allowed through. Behind the jet bore the fuel mixes with air which is supplied via cross ducts in the jet throat from the atomizing air duct, the amount of air admitted being determined by the setting of the mixture control screw (6). This initial mixture then flows through the idling outlet bore (LA) and the bypass or transition passages (BP) into the choke tube where it is mixed further with pure air.

Idling should always be adjusted with the engine at operating temperature. First the mixture control screw is turned in fully clock-wise and then backed off by the number of turns specified for the particular engine. Turning in clockwise direction results in a richer mixture and turning in anti-clockwise direction in a leaner mixture.

The idling setting quoted serves as a guide only. The optimum will generally differ slightly. First select the desired idling speed by using the throttle slide adjusting screw (13). The mixture control screw is then opened (turned anti-clockwise!) until the speed rises. Then turn the screw back by a quarter of a turn.

If the throttle slide is closed down to the idling position while the engine is running, then only the idling outlet bore (LA) is available between throttle slide and engine intake and it is thus exposed to the suction effect. When the throttle slide is in this position, air will enter through the bypass bore (BP) which will make the pre-mixture leaner until the idling speed is reached. If the throttle slide is then opened, the bypass bore will also be subject to the vacuum and supply additional fuel to enrich the mixture in the transition range.

Idling may be adjusted only by turning the setting screw (13) and the mixture control screw (6) or by using idling jets of various size. Idling outlet bore (LA) and bypass bore (BP) are matched to the fuel requirements of any given engine and must not be changed.

### Starting aids

Depending on application the BING carburettor type 54 may be provided with three different starting aids:

1. Tickler

When starting at low temperatures, the float may be pushed below the fuel level in the float chamber by depressing the tickler (34) against the spring (35) so that more fuel is supplied than normally necessary. The tickler may be operated only until fuel is seen to emerge from the float chamber vent (E) or becomes visible in the vent hose (54).

2. Air slide

The air slide (37) runs in a compartment of the throttle slide (8); it is moved by Bowden cable against the spring (38). When the slide projects into the choke tube, its cross-section is reduced and the vacuum at the needle jet outlet is increased. This enriches the mixture which is generally the aim when starting the engine.

3. Starting carburettor

The starting carburettor is a slide carburettor of simplest design which works in parallel to the main carburettor. When the slide consisting of the starting plunger (39) and the sleeve (40) located in the union (42) is lifted by a Bowden cable against the spring (41), then the starting plunger opens the fuel outlet which was previously closed by the seal on the underside of the plunger. At the same time the sleeve (40) opens a duct which allows air from the filter side of the throttle slide (8) to reach the motor side. This starting air is mixed with fuel in the starting car-

burettor, the fuel having been drawn in through the starting jet in the float chamber (28) and the riser in the starting carburettor. During starting the throttle slide must be closed!

The riser is immersed into a vented compartment of the float chamber (28); with the engine at a standstill and also during normal operation the fuel level in this compartment will be the same as in the float chamber. When starting with opened-up starting carburettor, the fuel will initially be drawn in from this compartment which forms a very rich mixture. The fuel supplied subsequently will only be the amount allowed through by the starting jet in the float chamber. This ensures that, once the engine has started, it is not supplied with an excessively rich mixture and stalled. The starting carburettor is therefore matched to any given engine by modifying the starting jet and matching the space behind it.

The starting cable is adjusted by an adjusting screw (19) with lock nut (20). The seal between adjusting screw and cable is provided by a rubber bush (21).

The starting carburettor may also be operated by the lever (50). For this the plate on which it pivots is secured to the carburettor housing by means of screws (51), nuts (53) and lock washers (52). The fork at one end engages with the starting plunger (46) which replaces the starting plunger (39) with sleeve (40). It is located in the union (48) and sealed against it by the rubber cap (49). When the engine is started from cold, the operating lever is depressed; this will open the starting carburettor against the spring (47).

